

A DIRECT QUADRATURE MODULATOR IC FOR 0.9 TO 2.5 GHZ WIRELESS SYSTEMS

Introduction

As wireless system designs have moved from carrier frequencies at approximately 900 MHz to wider bandwidth applications like Personal Communication System (PCS) phones at 1.8 GHz and wireless local area networks at 2.4 GHz, designers have been forced to implement discrete RF designs because of the absence of RF integrated circuits (RFICs) at these higher frequencies. System designs at these higher frequencies have a great need for highly integrated RFICs for quadrature modulators, power amplifiers, and low noise amplifiers/mixers.

Foreseeing the wireless expansion to higher data rates and higher carrier frequencies, RF Micro Devices initiated a product development schedule for RFICs for use in these applications. The first of these high-frequency products is the RF2422 direct quadrature modulator. This low-cost, high performance quadrature modulator (see Figure 1) operates from carrier frequencies of 0.9 to 2.5 GHz and integrates a 90° carrier phase shift network, limiting amplifiers, two doubly-balanced mixers, a summing amplifier, and an output stage that drives 50 ohms. The unit features operation from a single 5 volt power supply, a built-in standby power supply switch, and is packaged in a 16-lead small outline integrated circuit (SOIC).

gain at high frequencies. The process also provides thin-film resistors and high-Q metal-insulator-metal (MIM) capacitors. Thin film resistors possess excellent matching which is important in a quadrature modulator design where the I and Q circuitry must be identical. MIM capacitors allow the IC designer to implement DC blocking and filtering on chip instead of requiring the system designer to provide these externally. Another extremely important aspect of GaAs HBT is the semi-insulating substrate. The semi-insulating substrate results in negligible metal-to-substrate parasitics which means less high frequency crosstalk and leakage, and superior grounding.

Operation and Performance

The function of a quadrature modulator (also known as a vector or I/Q modulator) is to modulate a high-frequency carrier with lower frequency data. The beauty of a quadrature modulator is that it can be used to create all forms of analog and digital modulation. Amplitude, phase, and frequency modulation can all be implemented with a quadrature modulator. In order to evaluate the performance of a quadrature modulator, it is necessary to choose a specific modulation that is easy to generate and that allows the user to judge the important characteristics of the modulator. In general, RFIC manufacturers and users have settled on sinusoidal single sideband suppressed carrier (SSB or SSBSC) modulation.

SSB modulation allows the user to evaluate several important characteristics of a quadrature modulator: output power, carrier suppression, image suppression (phase and amplitude error), and harmonic distortion. To implement SSB modulation is a relatively simple task. The user connects a sinusoidal carrier to the local oscillator (LO) input of the modulator at the frequency of transmission. The I and Q ports are each driven with sinusoids of equal frequency and amplitude that are in phase quadrature with each other. The frequency used should reflect the data rate that will be used in the system. The output of the modulator is viewed with a spectrum analyzer centered at the carrier frequency. This method of evaluating modulator performance is inexpensive and fast for manufacturers and simple for end users to utilize.

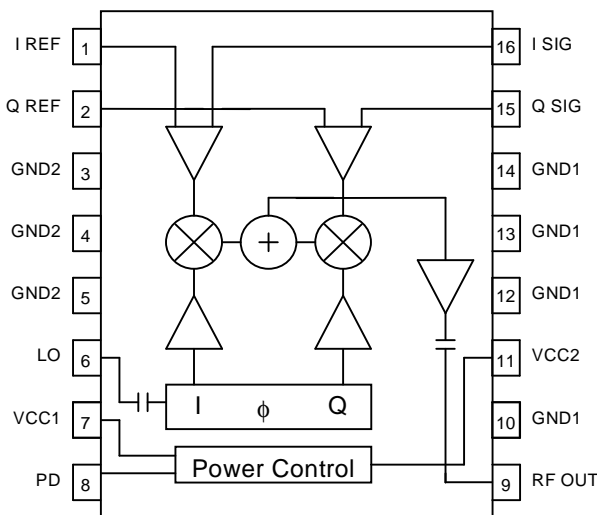

Figure 1. RF2422 Functional Block Diagram

The RF2422 is implemented using TRW's advanced Gallium Arsenide Heterojunction Bipolar Transistor (GaAs HBT) process. There are many features of this high performance process that make it ideal for the RF2422. First, the process features transistors with f_T of approximately 25 GHz. This high f_T allows the IC designer to use fewer devices and less current to attain

A typical SSB output spectrum is shown in Figure 2. Proceeding from right to left, the frequency spikes represent the upper sideband, the carrier, the lower sideband, and harmonic distortion. The upper sideband is, of course, the desired output and the other responses are all unwanted. The power level of the upper sideband, measured using a spectrum analyzer, is defined as the SSB output power. Raising and lowering

A DIRECT QUADRATURE MODULATOR IC FOR 0.9 TO 2.5 GHZ WIRELESS SYSTEMS

the amplitudes of the I and Q signals will raise and lower the output power. The LO level should be kept constant and not used to change output power. Figure 3 shows a graph of I/Q amplitude versus output power with an LO level of -5 dBm at 2 GHz.

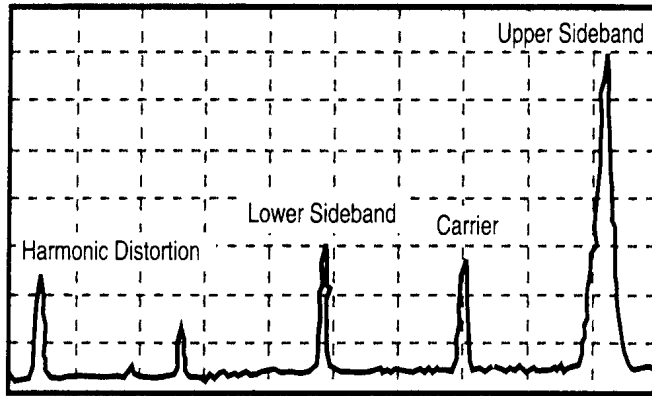

Figure 2. Typical SSB Output Spectrum

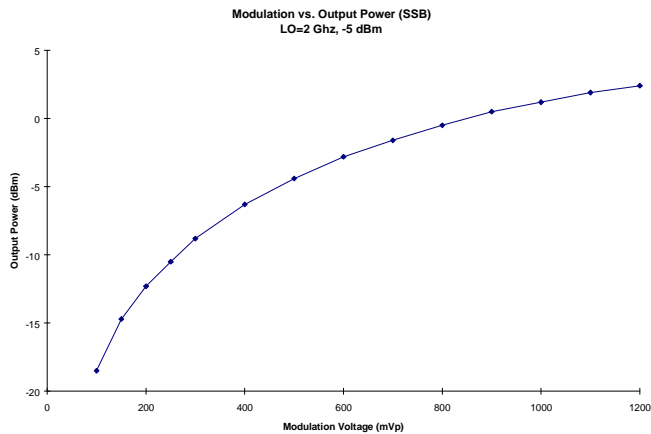

Figure 3. Modulation vs. Output Power (SSB); LO=2 GHz, -5 dBm

The frequency spike immediately left of the upper sideband is the carrier. The difference in power between the upper sideband and the carrier (in dB) is the carrier suppression. Carrier suppression is determined by the DC voltage matching between the ISIG, IREF, QSIG, and QREF pins, and by the amount of LO leakage to the output. The DC voltages at the I and Q input pins control the DC currents in the I and Q mixers. In order for the carrier to be suppressed, these currents must be identical. If the user provides DC voltages at the four I and Q input pins that are identical, then the RF2422 exhibits excellent carrier suppression. This is due to the superior matching of thin-film resistors in TRW's process. As mentioned before, suppression is also affected by LO leakage through the package and PC board. The higher the carrier frequency, the worse this

problem becomes. Even with leakage, carrier suppression can be optimized by adjusting DC voltages at the I and Q inputs relative to each other. Generally, adjustments of just a few millivolts will allow the user to null the carrier. It is important to note that carrier suppression is a relative measurement in that it is dependent on SSB output power. As I and Q modulation levels are decreased, the SSB output power will decrease, but the carrier will not, thus yielding less carrier suppression. It follows that users must be sure of what modulation levels are being used whenever reading a manufacturer's carrier suppression data. Figure 4 illustrates that carrier suppression in the RF2422 is typically below -30 dBc across the operating frequency range, without any adjustment. Note: The I and Q ports were each driven with 500 mV_{pk}.

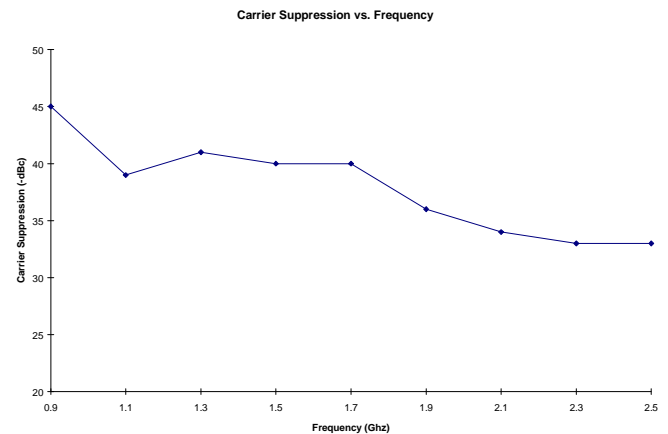

Figure 4. Carrier Suppression vs. Frequency

The next frequency spike is the lower sideband. The difference in power between the upper sideband and the lower sideband (in dB) is the image suppression. Image suppression is an indicator of phase and amplitude error. The more the phase and amplitude error, the worse the image suppression. These errors are caused by such things as package parasitics, nonlinear transistor operation, and layout asymmetry. Although these problems are addressed in design, they can never be completely eradicated. Amplitude and phase errors are largely frequency dependent, but they can also depend in a lesser extent on LO power level and power supply voltage. It is very important to evaluate the modulator under system operating conditions. Image suppression can be adjusted externally by changing the phases and amplitudes of I and Q relative to each other. Phase error in the RF2422 is very minimal. As shown in Figure 5a, phase error is typically within a few degrees at any given frequency. Amplitude error (Figure 5b) is only a few tenths of a dB at the frequency extremes. These small phase and amplitude errors combine to yield image

A DIRECT QUADRATURE MODULATOR IC FOR 0.9 TO 2.5 GHZ WIRELESS SYSTEMS

suppression numbers that typically range in the mid 30s, as shown in Figure 5c.

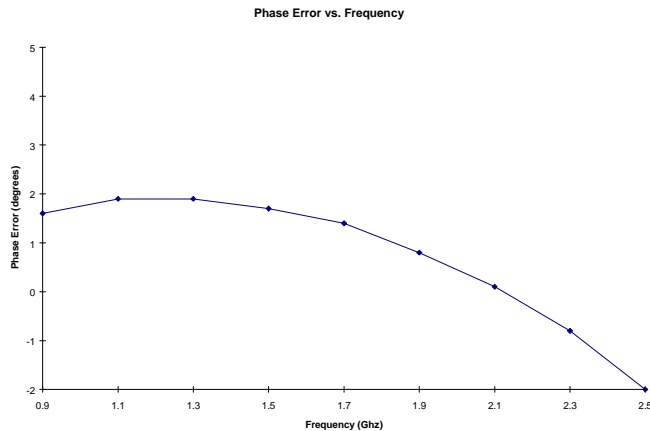

Figure 5a. Phase Error vs. Frequency

The two frequency spikes furthest to the left are harmonic distortion. Although there are other spurious products that can be viewed if the spectrum is spanned at higher frequencies, these specific products are the closest to the carrier with the most power, and therefore the most difficult to filter. In addition, manufacturers usually only specify the suppression of the distortion spike furthest to the left since it is stronger than the one that is closer in. As the amplitudes of the I and Q signals are increased, the power of this harmonic will increase, much like an IM_3 product. Like the carrier and the lower sideband, system designers prefer harmonic distortion to be kept to a minimum to prevent saturation of the power amplifier or any components in the receiver.

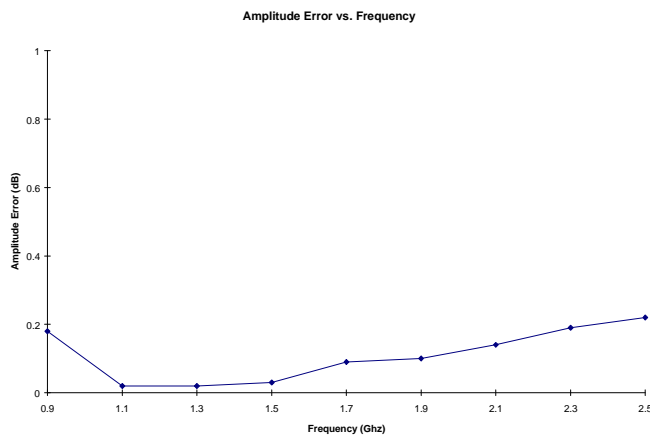

Figure 5b. Amplitude Error vs. Frequency

Image Suppression vs. Frequency

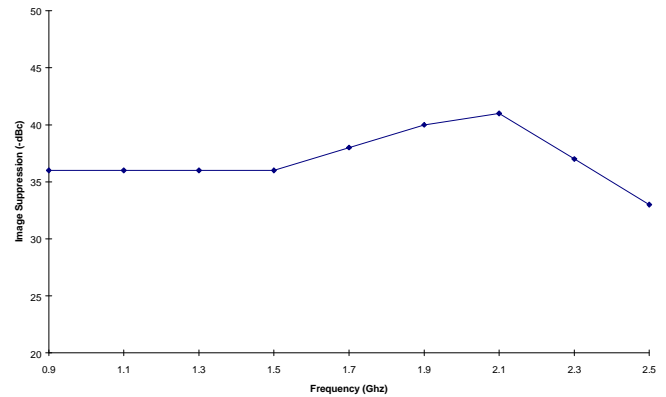

Figure 5c. Image Suppression vs. Frequency

Description of Design

The LO connection to the RF2422 is a single-ended, 50 ohm termination so that no transformer or balun is needed. The port is DC blocked internally so that no external blocking capacitor is needed. Having entered the part, the LO signal immediately travels through an R-C network that acts as a phase splitter. The R-C network consists of a high-pass and a low-pass filter which each shift the LO signal 45 degrees, but in opposite directions. The result is that the LO signal is split into two signals of equal frequency but 90 degrees out of phase. The output of one filter will propagate to the I mixer while the output of the other filter will go to the Q mixer. The R-C network is designed around a 2 GHz center frequency so that when the LO signal is below 2 GHz, the high-pass filter attenuates the amplitude of its signal; likewise for the low-pass filter when the LO is above 2 GHz. In order to equalize the two filter outputs, limiters must be used after the R-C networks.

Each of the two limiter stages consists of a high-gain differential amplifier. The limiters' function is to amplify the two quadrature signals to the point where the waveforms are clipping. The clipping effectively equalizes the two signals since both limiters are designed identically and will clip at the same time. Obviously, if the LO signal is low enough in power or far enough in frequency from 2 GHz, the limiters will not be able to equalize the two signals, causing a transmission amplitude error. The recommended LO power level for the RF2422 is -5 dBm.

The quadrature LO signals proceed to the I and Q mixers where they are each coupled to the top four transistors in a Gilbert cell. Because the signals are high amplitude square waves, the top transistors act like high speed switches. The bottom differential pair of each of the mixers (Gilbert cells) act as the inputs for the lower

A DIRECT QUADRATURE MODULATOR IC FOR 0.9 TO 2.5 GHZ WIRELESS SYSTEMS

frequency modulating signals. In the I mixer, these input pins are referred to as ISIG and I REF; in the Q mixer as QSIG and QREF. There is no DC blocking on any of these inputs; each input effectively looks into the base of a transistor. This translates to a very high impedance looking into each input (approximately 30 K ohms), and therefore these ports will draw very little DC current (40 μ A) unless the part is operated in saturation mode. Saturation occurs when the voltage at these inputs approaches $4 V_{DC}$. When the voltages at these pins approach $1.5 V_{DC}$, the transistor current sources associated with each of the Gilbert cells begin to saturate, causing nonlinear operation. From this information it is clear that for linear operation the I and Q pins should be driven with signal levels between 1.5 to $4 V_{DC}$. The recommended offset voltage is from 2.5 to $3 V_{DC}$. In order to boost the input compression point of the mixers, emitter degeneration is used in the bottom differential pair of each mixer.

The output currents of the two mixers are summed at the collectors across two load resistors. The summed outputs are then amplified by a differential amplifier which acts as a driver to the output stage. Emitter degeneration is once again used for maximum linearity.

The output stage is required to convert the differential output from the driver to a single-ended signal. In order to keep current consumption to a minimum, a push-pull

configuration is used. The output impedance is designed to look like 50 ohms across the frequency operating range.

External Components

The RF2422 is extremely easy to insert into a wireless system. Only three external components are required to make the RF2422 fully operational. All three components are bypass capacitors. Two capacitors are needed to bypass the VCC1 and VCC2 pins and the third capacitor is used to bypass IREF and QREF if the baseband-to-I/Q connections are single-ended (IREF and QREF would be tied together in this case). If IREF and QREF are being used in a differential connection,

then no bypass capacitor would be needed for those pins. As with all RF board designs, bypass capacitors should be placed as close as possible to the part.

The LO port has a 50 ohm input impedance and is generally coupled to a synthesizer with 50 ohm microstrip. Although an input level of -5 dBm is suggested for the LO input, this number is not critical for operation. In fact, the part will continue to operate at levels less than -10 dBm, but with less conversion gain and degraded amplitude accuracy. Therefore, the match between the LO port and the synthesizer may or may not be important, depending on system requirements. The output impedance of the RF2422 is 50 ohms and is usually coupled to a power amplifier or driver with 50 ohm microstrip. There is an internal DC block so that no external series capacitor is needed. Generally the match between the output and the following amplifier is quite important, so as to achieve maximum power transfer. If the input impedance of the following power amplifier is a 50 ohm termination, then no extra matching components are needed between the two unless DC blocking is required for the amplifier.

The PD pin is used to power down the part when operation is not needed. For example, in time division duplex (TDD) systems where the transmitter and receiver are operated in alternating time slots, the RF2422 could be powered down when the receiver is in use to minimize current consumption and thus extend battery life on handheld units. The PD pin can be directly driven with a CMOS driver where $+5 V_{DC}$ powers up the part and ground powers it down.

The modulation input pins of ISIG, IREF, QSIG, and QREF can be driven with any modulating waveforms. ISIG and IREF are differential inputs to the I mixer on the RF2422 as QSIG and QREF are differential inputs to the Q mixer. For carrier suppression, the DC voltages at all four pins must be equal.

A DIRECT QUADRATURE MODULATOR IC FOR 0.9 TO 2.5 GHZ WIRELESS SYSTEMS

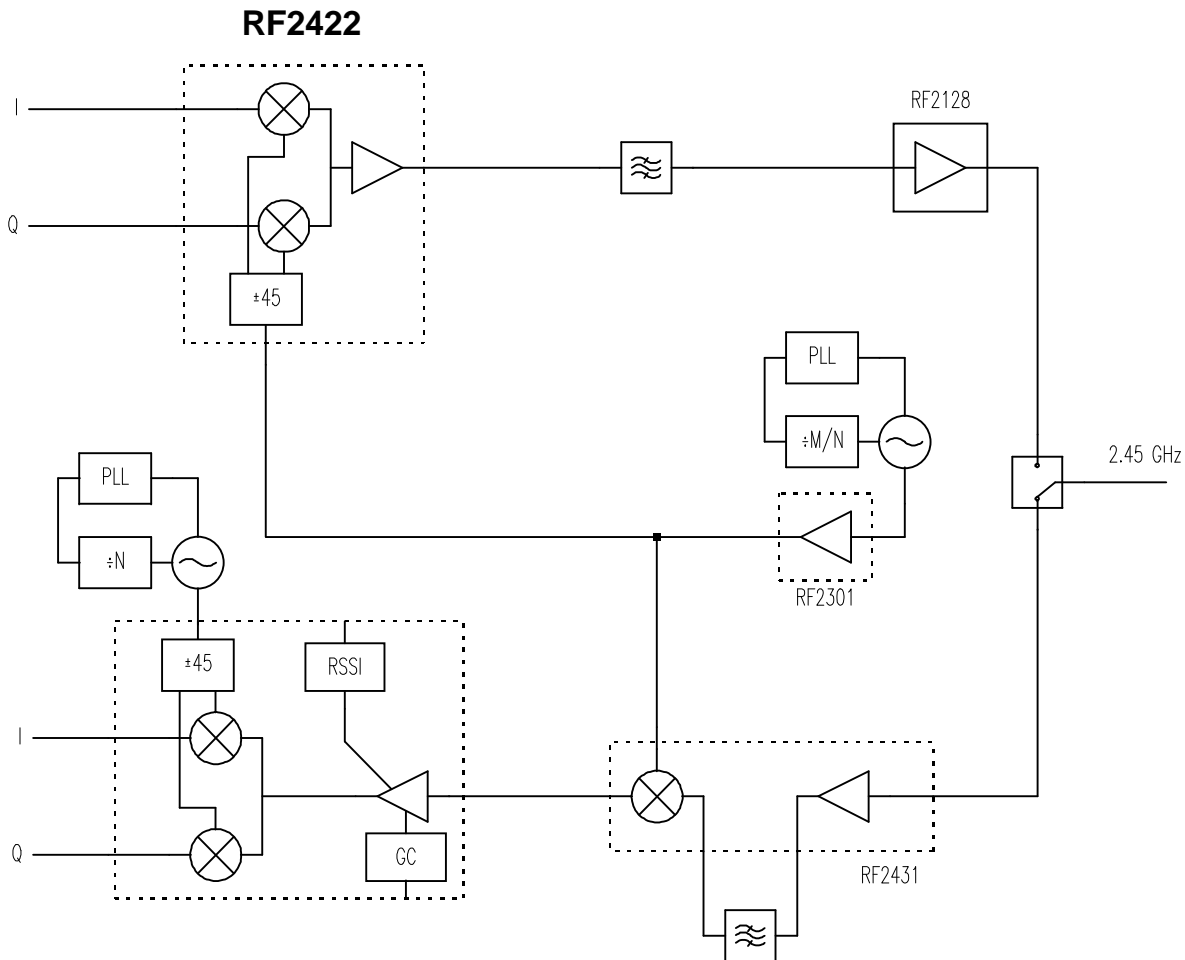

Figure 6. A Simplified Wireless LAN System Block Diagram

Applications

Wireless local area networks using direct-sequence spread-spectrum modulation can successfully use the RF2422 as illustrated in the simplified system block diagram in Figure 6. In the transmitter, I and Q baseband data are first modulated by a pseudo-random bit code that is much higher in frequency than the I/Q data. Once this frequency spreading has taken place, the resulting signals are fed into the I and Q inputs of the RF2422. The RF2422 enables the spread signals to perform what is typically GMSK or QPSK modulation directly onto a 2.45 GHz carrier. This approach eliminates much of the filtering and LO requirements necessary for multiple upconversion schemes. Other applications include PCS and DCS1800 digital systems operating at 1.8 to 2 GHz, and satellite communications systems operating in L-band.

Conclusion

The RF2422 direct quadrature modulator fills an important gap in 2 GHz wireless systems. Direct modulation up to 2.5 GHz is now possible with a proven chip that can greatly simplify a wireless transmitter. The RF2422 packs numerous discrete functions into one small SOIC package so that system designers can reduce size, cost, and valuable engineering time.

This article was originally presented in *RF Design*; August 1994.

Author: William H. Pratt
 Design Engineer
 RF Micro Devices, Inc.